



## 42-inch High Definition Plasma Display TH-42PH20ER

### Product specification (design and specification subject to change without notice)

#### DISPLAY

Screen Size (Diagonal)	42-inch (1,057 mm)
Aspect Ratio	16:9
Effective Display Area (W x H)	921 x 518 mm
Number of pixels (H x V)	1,024 x 768 pixels (1 pixel=3 cells for R, G and B)
Pixel Pitch (H x V)	0.900 x 0.675 mm
Brightness (Panel)	1,400 cd/m <sup>2</sup>
Contrast Ratio (Bright room)	2,000,000:1 (400:1)
Gradation	5,120 steps (equivalent)

#### CONNECTION TERMINAL

VIDEO IN	BNC x 1	1.0 V [p-p] (75 Ω)
AUDIO IN (L/R)	RCA pin jack x 1 set	0.5 V [rms]
COMPONENT/RGB IN	BNC x 3	Y/G : with sync 1.0 V [p-p] (75 Ω) B/Pb/Cb, R/Pr/Cr : 0.7 V [p-p] (75 Ω)
AUDIO IN (L/R)	RCA pin jack x 1 set	0.5 V [rms]
HDMI IN	HDMI TYPE A connector x 1	
DVI-D IN	DVI-D 24pin x 1	Compliance with DVI Revision 1.0 Compatible with HDCP 1.1
AUDIO IN	M3 jack x 1	0.5 V [rms]
PC IN	MINI D-SUB 15PIN x1 (Female)	Y/G : with sync 1.0 V [p-p] (75 Ω) without sync 0.7 V [p-p] (75 Ω) B/Pb/Cb, R/Pr/Cr : 0.7 V [p-p] (75 Ω) HD/VD : 1.0~5.0 V [p-p] (high impedance)
AUDIO IN	M3 JACK x 1	0.5 V [rms]
SERIAL	D-SUB 9PIN x 1 (EXTERNAL CONTROL TERMINAL), RS-232C COMPATIBLE	
Function Slot:SLOT 2.0	1 (Vacant)	

#### ELECTRICAL

Power Requirements	220-240 V AC, 50 Hz/60 Hz
Power Consumption	275 W
On Mode Average Power Consumption*	160 W
Power Off Condition	0.3 W
Stand-by Condition	0.6 W (Save ON) 1.1 W (Save OFF)

\*Based on IEC 62087 Ed.2 measurement method.

#### AUDIO

Audio Output	16 W [8 W + 8 W] (10 % THD)
--------------	-----------------------------

#### MECHANICAL

Dimensions (W x H x D)	1,020 x 610 x 89 mm
Carton Dimensions (W x H x D)	1,138 x 721 x 284 mm
Weight	approx. 25.0 kg
Gross Weight	approx. 30.0 kg
Cabinet Color	Black

#### ENVIRONMENTAL

Operating Environment	Temperature: 0 °C to 40 °C
	Humidity : 20 % to 80 % (Non condensation)
	Altitude : 0 to 2,800 m
Storage Environment	Temperature: -20 °C to 60 °C
	Humidity : 20 % to 90 % (Non condensation)
	Altitude : 0 to 3,300 m

#### STANDARD (CERTIFICATIONS)

SAFETY REGULATIONS	EN60065 Ver.7, GOST 12.2.006-87, IEC60065
RADIATION REGULATIONS	EN55022 Class-B, EN55024 EN61000-3-2, EN61000-3-3

#### REMOTE CONTROL TRANSMITTER

Power Requirements	DC 3 V (2 x R6 Size batteries)
Operation Distance	approx. 7 m in front of plasma display
Weight	approx. 100 g including batteries

INCLUDED ACCESSORIES	- Clamper - AC power cord - Operating instruction book - Remote control transmitter - Batteries
----------------------	--

**MAIN FEATURE**

Multi Display	2 x 2, 3 x 3, 4 x 4, 5 x 5 n x m (Max 5 x 5)
Digital Zoom	x2, x3, x4
Display Size Setting	Yes
Weekly Command Timer	Yes
Automatic Picture Positioning	Yes
Screen Savers	NANODRIFT saver, Side Panel Adjustment Peak Limit Mode, Negative Image, Scrolling Bar only, White Screen, Overlay Scrolling Bar
Power Save Mode	Yes
Auto Power Off	Yes
Standby Power Save Mode	Yes
Input lock	Yes
Button lock	Yes
Maximum volume level	Yes
Remote user level	Yes

**OPTIONAL ACCESSORIES**

Pedestal	TY-ST20-K
Wall-hanging bracket	TY-WK42PV20
Wall-hanging bracket (angled)	TY-WK42PR20
Ceiling-hanging bracket	TY-CE42PS20
Mobile stand	TY-ST58PF20
Speakers	TY-SP42P8W-K
Touch Panel	TY-TP42P10S
Anti Glare Filter	TY-AR42P12W
HD-SDI (with audio) Terminal board	TY-FB10HD
Dual HDMI Terminal board	TY-FB10HMD
Dual Video Terminal board	TY-FB9BD
DVI-D Terminal board	TY-FB11DD
Ir Through board	TY-FB9RT

**DIMENSIONS**

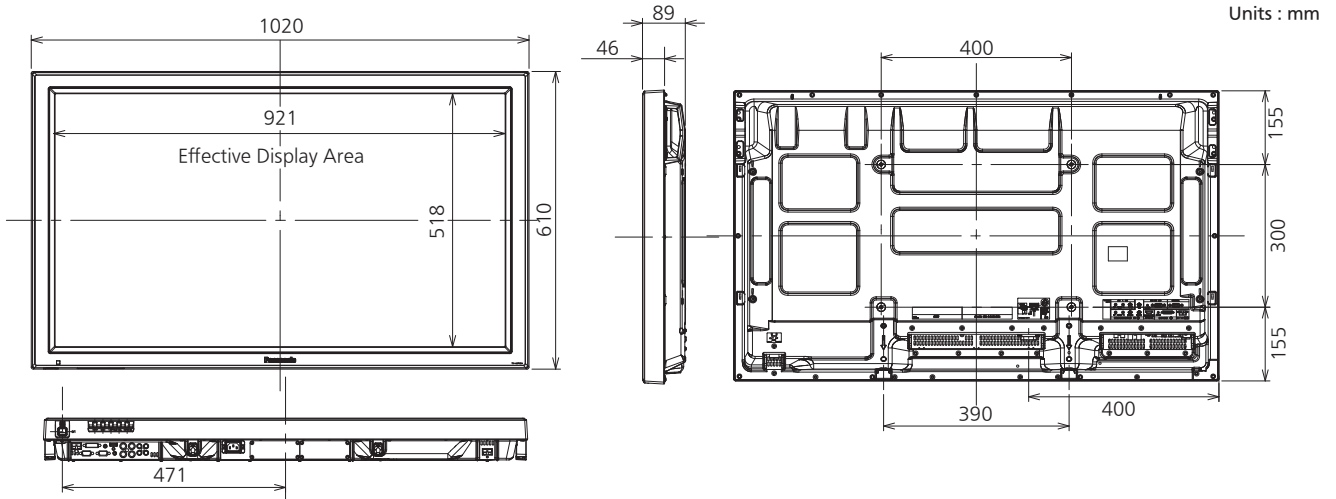

**TERMINAL DIMENSIONS**

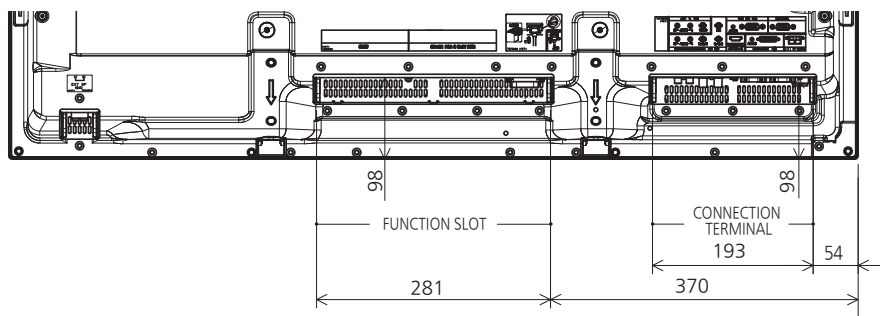

**FUNCTION SLOT**

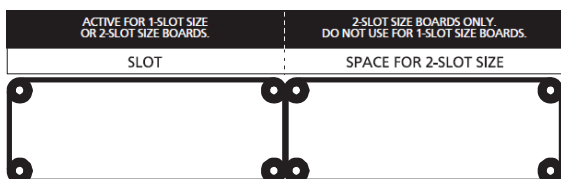

**CONNECTION TERMINAL**

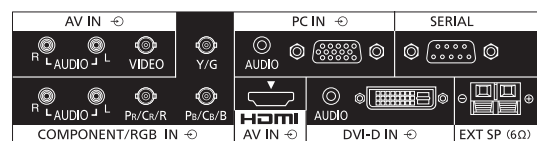

**● Preset Input Signals**

Signal name	horizontal frequency (kHz)	vertical frequency (Hz)	Fixed Terminal				Optional Board						
			Component Video	Composite Video	HDMI	DVI-D	PC IN (D-sub 15-pin)	BNC Dual Video (TY-FB98D)	DVI-D (TY-FB11DD)	HD-SDI with Audio (TY-FB10HD)	Dual HDMI (TY-FB10HMD)		
<b>Composite</b>													
NTSC	15.73	59.94		Y				Y					
PAL	15.63	50.00		Y				Y					
PAL60	15.73	59.94		Y				Y					
SECAM	15.63	50.00		Y				Y					
Modified NTSC	15.73	59.94		Y				Y					
<b>Component/RGB</b>													
525(480)/60i	15.73	59.94	Y		Y	Y	Y		Y				
525(480)/60p	31.47	59.94	Y		Y	Y	Y* 1</td <td></td> <td>Y</td> <td></td> <td></td> <td>Y</td> <td></td>		Y			Y	
625(575)/50i	15.63	50.00	Y				Y						
625(576)/50i	15.63	50.00			Y	Y					Y		
625(575)/50p	31.25	50.00	Y				Y						
625(576)/50p	31.25	50.00			Y	Y			Y			Y	
750(720)/60p	45.00	60.00	Y		Y	Y	Y		Y	Y	Y		
750(720)/50p	37.50	50.00	Y		Y	Y	Y		Y	Y	Y		
1125(1080)/60i	33.75	60.00	Y*2		Y	Y	Y*2		Y	Y	Y		
1125(1080)/60p	67.50	60.00	Y*2		Y	Y	Y*2		Y	Y	Y		
1125(1080)/50i	28.13	50.00	Y*2		Y	Y	Y*2		Y	Y	Y		
1125(1080)/50p	56.25	50.00	Y*2		Y	Y	Y*2		Y	Y	Y		
1125(1080)/30p	33.75	30.00	Y*2			Y	Y*2		Y	Y			
1125(1080)/25p	28.13	25.00	Y*2			Y	Y*2		Y	Y			
1125(1080)/24p	27.00	24.00	Y*2		Y	Y	Y*2		Y	Y	Y		
1125(1080)/24sF	27.00	48.00	Y*3				Y*3				Y		
1250(1080)/50i	31.25	50.00	Y*4				Y*4						
<b>RGB</b>													
640×400@70Hz	31.46	70.07	Y				Y						
640×480@60Hz	31.47	59.94	Y*5		Y	Y	Y		Y				Y
640×480@72Hz	37.86	72.81	Y				Y						
640×480@75Hz	37.50	75.00	Y				Y						
640×480@85Hz	43.27	85.01	Y				Y						
800×600@56Hz	35.16	56.25	Y				Y						
800×600@60Hz	37.88	60.32	Y		Y	Y	Y		Y				
800×600@72Hz	48.08	72.19	Y				Y						
800×600@75Hz	46.88	75.00	Y				Y						
800×600@85Hz	53.67	85.06	Y				Y						
852×480@60Hz	31.47	59.94	Y*5			Y	Y		Y				
1024×768@50Hz	39.55	50.00					Y						
1024×768@60Hz	48.36	60.00	Y		Y	Y	Y		Y				
1024×768@70Hz	56.48	70.07	Y				Y						
1024×768@75Hz	60.02	75.03	Y				Y						
1024×768@85Hz	68.68	85.00	Y				Y						
1066×600@60Hz	37.64	59.94	Y			Y	Y		Y				
1152×864@60Hz	53.70	60.00				Y			Y				
1152×864@75Hz	67.50	75.00	Y				Y						
1280×768@60Hz	47.70	60.00	Y				Y						
1280×960@60Hz	60.00	60.00	Y				Y						
1280×960@85Hz	85.94	85.00	Y				Y						
1280×1024@60Hz	63.98	60.02	Y		Y	Y	Y		Y				
1280×1024@75Hz	79.98	75.03	Y				Y						
1280×1024@85Hz	91.15	85.02	Y				Y						
1366×768@50Hz	39.55	50.00					Y		Y				
1366×768@60Hz	48.36	60.00	Y				Y	Y	Y				
1400×1050@60Hz	65.22	60.00					Y		Y				
1600×1200@60Hz	75.00	60.00	Y				Y	Y	Y				
1600×1200@65Hz	81.25	65.00	Y				Y						
1920×1080@60Hz	67.50	60.00	Y*6				Y*6	Y*6	Y*6				
1920×1200@60Hz	74.04	59.95					Y		Y				
Mac13" (640×480)	35.00	66.67	Y				Y						
Mac16" (832×624)	49.72	74.54	Y				Y						
Mac21" (1152×870)	68.68	75.06	Y				Y						

\*1:When selected the RGB format and 525p signal input, it is recognized as VGA 60Hz signal. \*2:Based on SMPTE 274M standard. \*3:Based on SMPTE RP211 standard. \*4:Based on SMPTE 295M standard. \*5:When inputted VGA 60 Hz format signal, it is recognized as 525p signal. \*6:Recognized as 1,125(1,080)/60p signal. Note:Signals without above specification may not be displayed properly.

**● Pin assignments and signal names**

Serial RS232C : D-sub 9-Pin (Male)



No.	Signal name	Descriptions
1	CD	NC
2	RXD	Receive Data
3	TXD	Transmit Data
4	DTR	Not used
5	GND	Ground
6	DSR	Not used
7	RTS	Shorted in this set
8	CTS	
9	RI	NC

\*These signal names are those of computer specifications.

PC Input : D-Sub 15-Pin (Female)

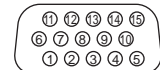

No.	Signal name
1	R (P <sub>R</sub> /C <sub>R</sub> )
2	G (Y)
3	B (P <sub>B</sub> /C <sub>B</sub> )
4	NC (Not connected)
5	GND (Ground)
6	GND (Ground)
7	GND (Ground)
8	GND (Ground)
9	+5V DC
10	GND (Ground)
11	NC (Not connected)
12	SDA
13	HD/SYNC
14	VD
15	SCL

DVI-D Input Terminal

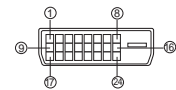

No.	Signal name	No.	Signal name
1	T.M.D.S. data 2-	13	—
2	T.M.D.S. data 2+	14	+5 V DC
3	T.M.D.S. data 2 shield	15	Ground
4	—	16	Hot plug sense
5	—	17	T.M.D.S. data 0-
6	DDC clock	18	T.M.D.S. data 0+
7	DDC data	19	T.M.D.S. data 0 shield
8	—	20	—
9	T.M.D.S. data 1-	21	—
10	T.M.D.S. data 1+	22	T.M.D.S. clock shield
11	T.M.D.S. data 1 shield	23	T.M.D.S. clock+
12	—	24	T.M.D.S. clock-

HDMI Terminal

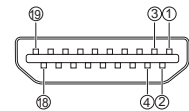

No.	Signal	No.	Signal
1	T.M.D.S. data 2+	11	T.M.D.S. clock shield
2	T.M.D.S. data 2 shield	12	T.M.D.S. clock-
3	T.M.D.S. data 2-	13	CEC
4	T.M.D.S. data 1+	14	Reserved (N.C. on device)
5	T.M.D.S. data 1 shield		
6	T.M.D.S. data 1-	15	SCL
7	T.M.D.S. data 0+	16	SDA
8	T.M.D.S. data 0 shield	17	DDC/CEC Ground
9	T.M.D.S. data 0-	18	+5 V DC
10	T.M.D.S. clock+	19	Hot Plug Detect